

Draw Box

1350mm

Our polyethylene junction boxes are robust, non-conductive underground cable joining chambers that are easy to install in a variety of configurations.

Side view

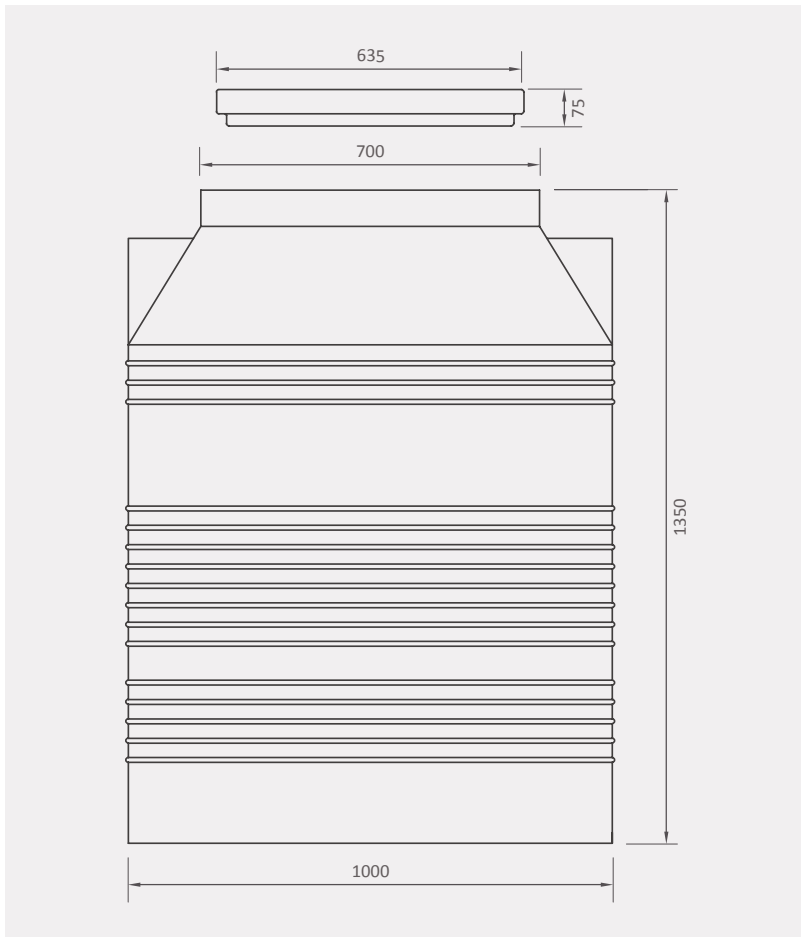

Top view

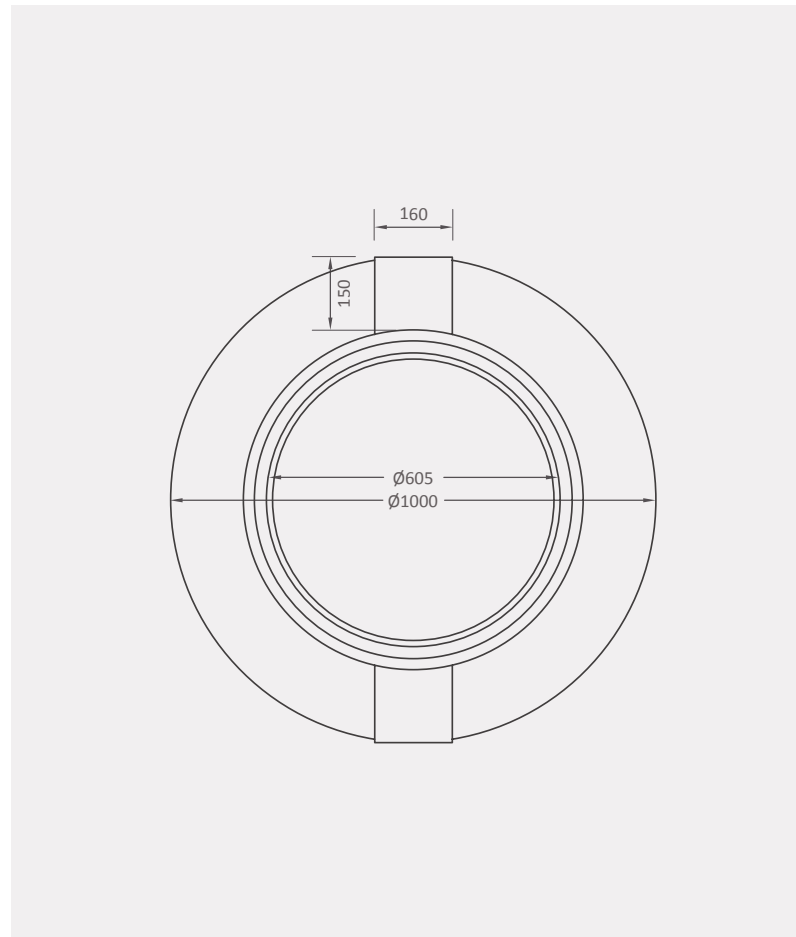

Product specifications:

Application:

- Cable joining below ground
- Pumping chamber for small wastewater systems

Supplied with:

- 1) 560mm lid

Connection size options:

- 32, 50, 110 or 160mm

Note: if no connections are requested, none will be added.

Optional extras for installation:

Rubber seal gasket/s for the preferred connection size/s (options available include 32, 50, 110 and 160mm), and a 560mm (d) by 150 or 500mm (h) lid extension (depending on requirements).

Note: these are not included as part of the product offering, but are available at an additional cost.

Availability:

Standard colour ●

10-year guarantee

All dimensions are in millimetres and the drawings are drawn on a scale of 1:75. The design is the property of Calcamite.