

## Greywater Basic

400L

Supplied pre-assembled and ready-for-installation, our domestic greywater systems have been designed with ease of operation and maintenance in mind.

Front view

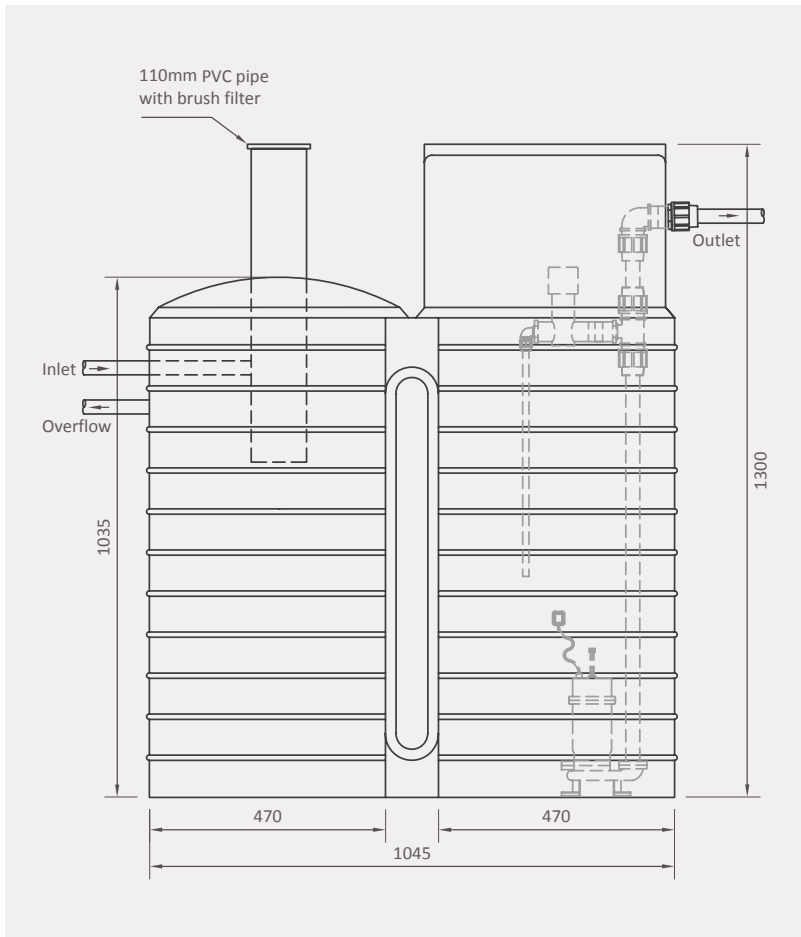

Top view

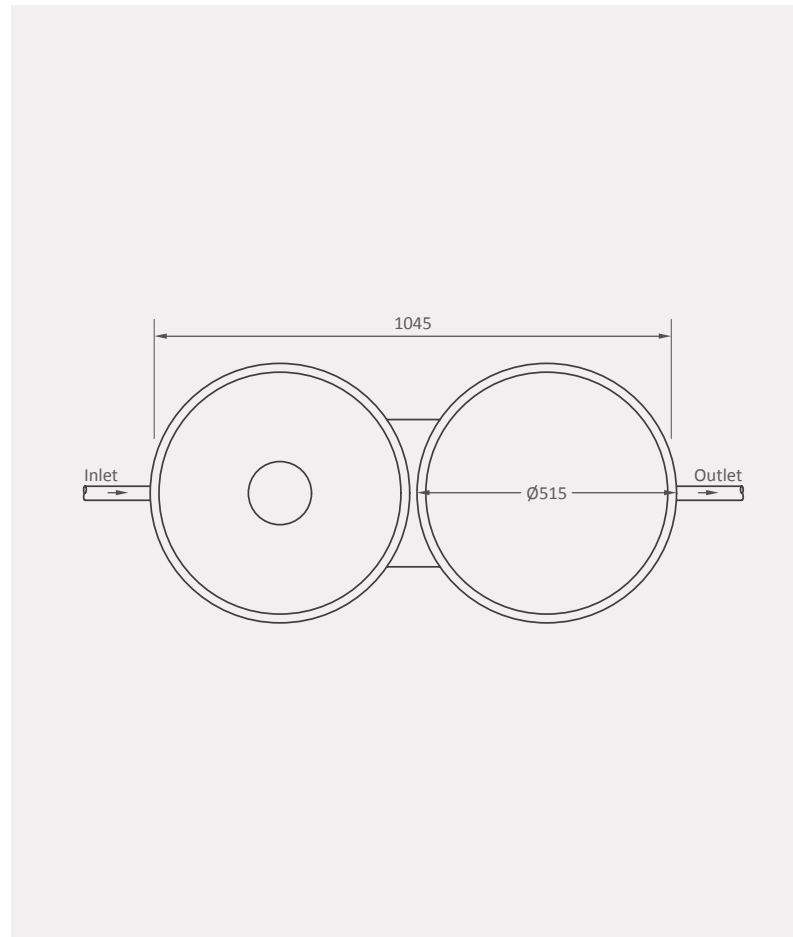

### Product specifications:

#### Capacity:

- Up to 10 people

#### Application:

- Below ground greywater system
- Allows you to manage and safely reuse domestic greywater for irrigation purposes

#### Supplied with:

- 1) 460mm lid
- 2) 300mm (h) lid extension
- 3) 110mm PVC pipe fitted with:
  - 110mm screw cap (rodding eye)
  - Brush filter
- 4) Inlet fitted with:
  - 50mm PVC socket
- 5) Overflow fitted with:
  - 50mm PVC socket
- 6) Outlet fitted with:
  - 40mm female compression fitting
- 7) Submersible pump (DAB Feka BVP750 with float switch)
- 8) Calcium hypochlorite dispenser complete with:
  - 1 x Cartridge

### Availability:

Standard colour ●

### 10-year guarantee

All dimensions are in millimetres and the drawings are drawn on a scale of 1:50. The design is the property of Calcamite.