

Greywater Mini

125L

Supplied pre-assembled and ready-for-installation, our domestic greywater systems have been designed with ease of operation and maintenance in mind.

Front view

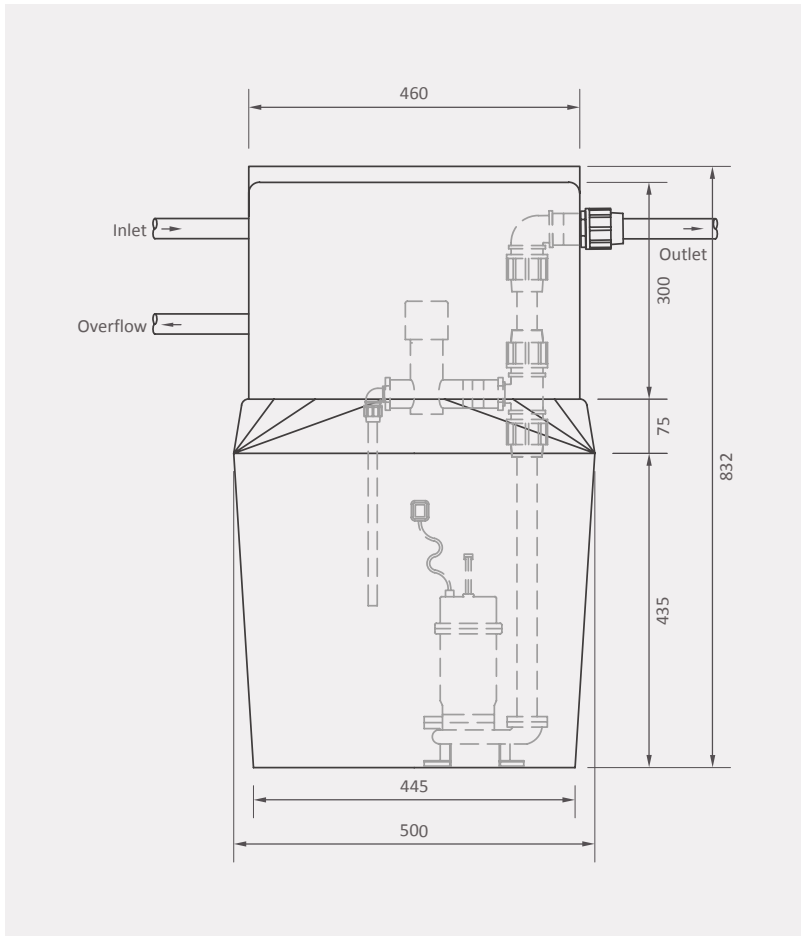

Top view

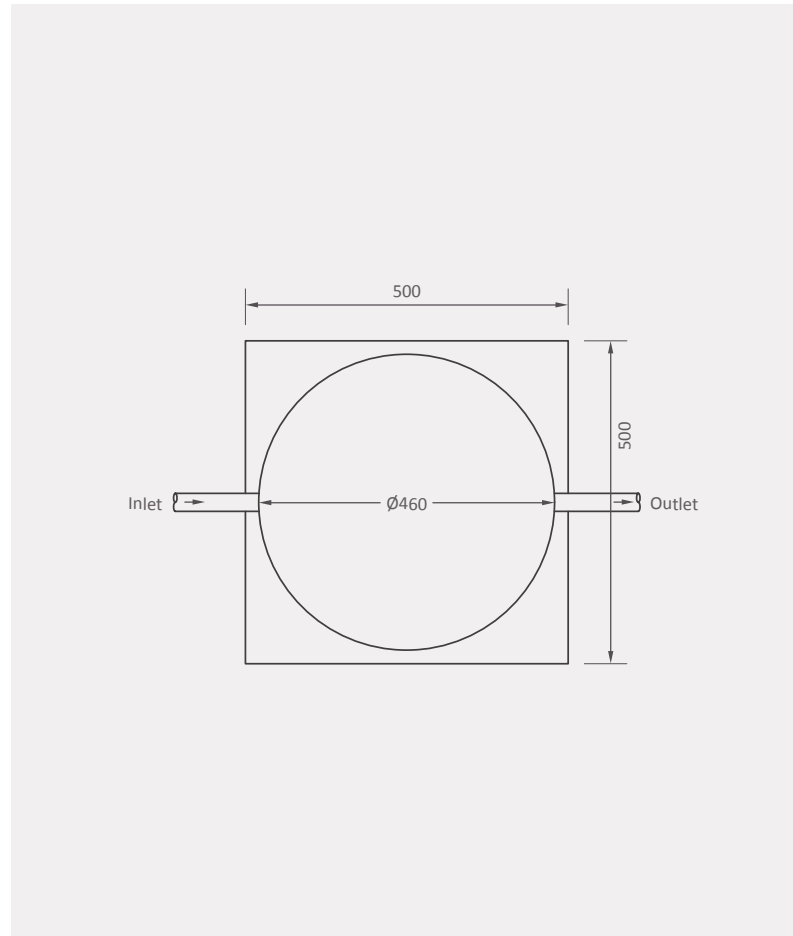

Product specifications:

Capacity:

- Up to 6 people

Application:

- Below ground greywater system
- Allows you to manage and safely reuse domestic greywater for irrigation purposes

Supplied with:

- 1) 460mm lid
- 2) 300mm (h) lid extension
- 3) Inlet fitted with:
 - 50mm PVC socket
- 4) Overflow fitted with:
 - 50mm PVC socket
- 5) Outlet fitted with:
 - 32/25mm socket
- 6) Submersible pump (DAB Feka BVP750 with float switch)
- 7) Calcium hypochlorite dispenser complete with:
 - 1 x Cartridge

Availability:

Standard colour ●

10-year guarantee

All dimensions are in millimetres and the drawings are drawn on a scale of 1:50. The design is the property of Calcamite.