

Pumping Chamber

1500L

Watertight, lightweight and abrasion-resistant, our unique pumping chambers are durable, simple to install and allow for easy customization according to your setup requirements.

Front view

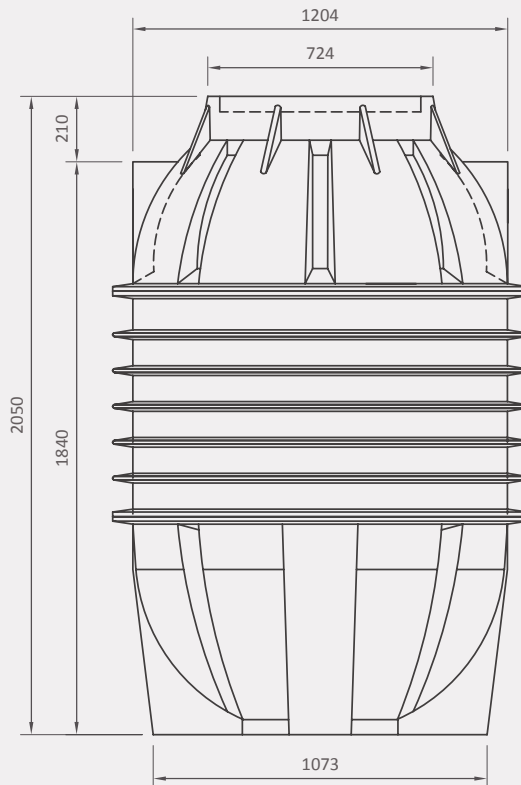

Top view

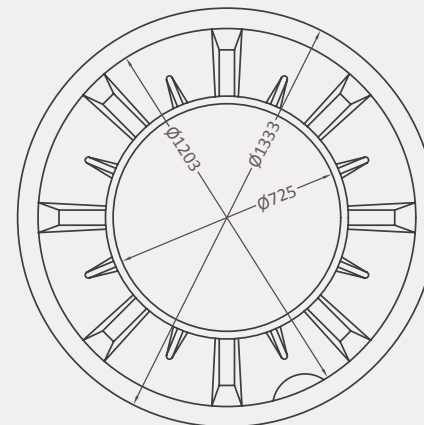

Product specifications:

Application:

- Underground pumping chamber
- Access point to collect and feed to an above ground wastewater treatment plant

Supplied with:

- 1) 560mm lid

Optional extras for installation:

Electrical submersible pump (according to specifications required), 560mm (d) by 300mm (h) lid extension, 110mm rubber seal ring/s and a 110mm PVC socket for the inlet.

Note: these are not included as part of the product offering, but are available on request.

Availability:

Standard colour ●

10-year guarantee

All dimensions are in millimetres and the drawings are drawn on a scale of 1:75. The design is the property of Calcamite.