

Septic Tank - Standard

3000L

Our distinctive septic tanks incorporate the use of a double chamber to ensure better hydraulic efficiency, cleaner effluent discharge, and an improved soak-away performance.

Front view

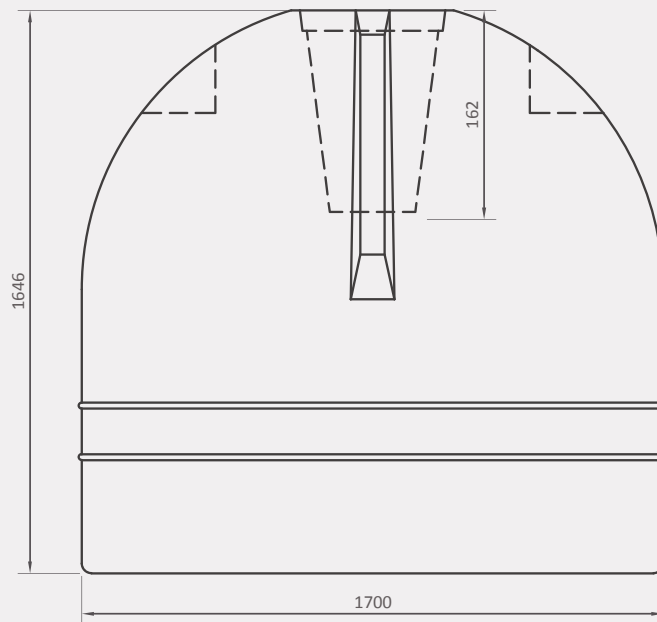

Top view

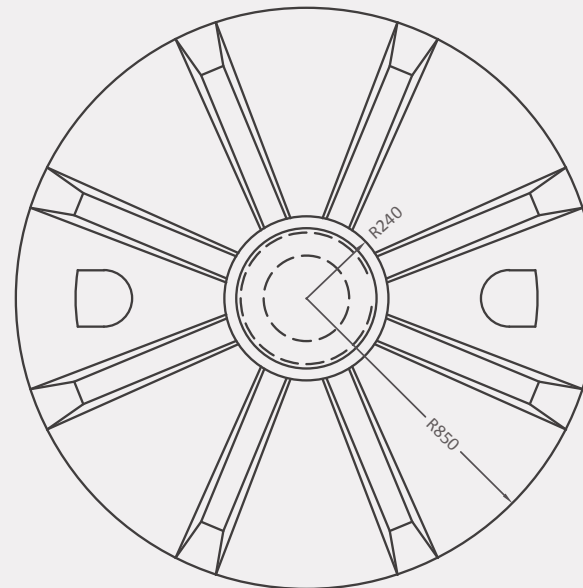

Product specifications:

Capacity:

- Maximum of 12 people assuming 200L per person per day

Application:

- Below ground
- Where connection to the sewer line is not feasible/possible
- Soils with a good percolation rate such as sandy soil
- Areas with a low water table in order to prevent contamination of groundwater sources

Supplied with:

- 1) 460mm lid
- 2) 50mm socket (for outlet)
- 3) 50mm rubber gasket (for outlet)
- 4) 110mm rubber gasket (for inlet)

Recommended additions

for installation:

110mm inlet junction, 110mm rodding eye and 460mm (d) x 300mm (h) lid extension.

Note: these are not included as part of the product offering, but are available at an additional cost.

Availability:

Standard colour ●

10-year guarantee

All dimensions are in millimetres and the drawings are drawn on a scale of 1:75. The design is the property of Calcamite.