

## Underground Modular Conservancy Tank

9500L

Often used as conservancy tanks, our modular range provides the opportunity of collecting and holding wastewater on site while preventing the contamination of groundwater. The stored wastewater is then collected periodically by a waste disposal company and transferred to a suitable treatment plant.

### Side view

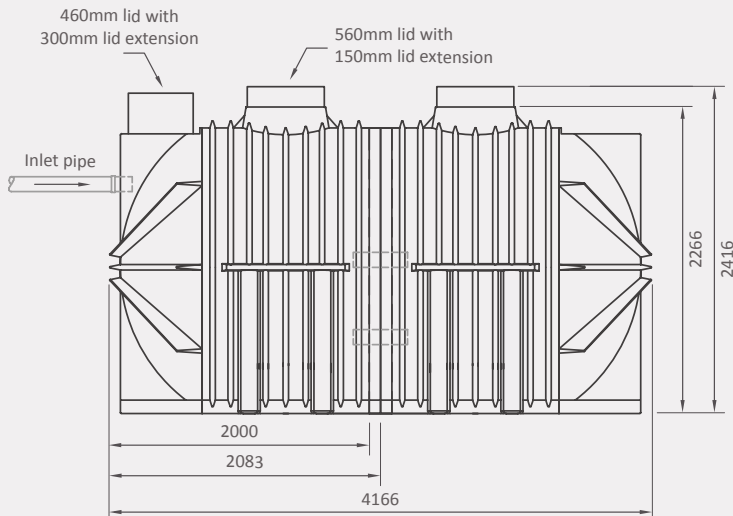

### Top view

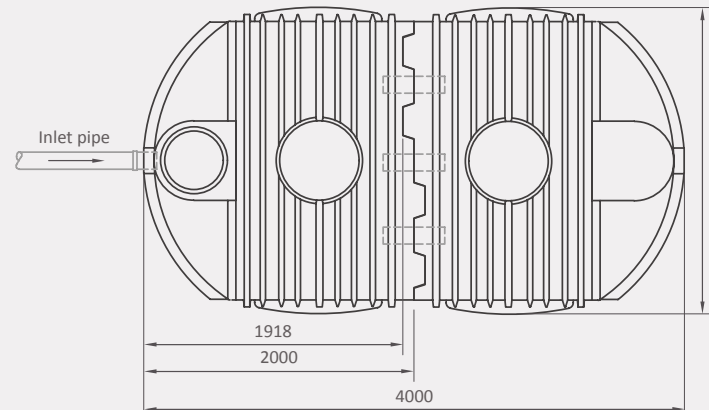

### Product specifications:

#### Application:

- Below ground
- Where connection to the sewer line or a soak-away/French drain is not feasible possible
- Not suited for clay type soils with a high-water table, or areas that are frequently flooded
- Not suited for use in the path of vehicles heavy equipment or where underground services are expected (i.e., electric cables, water and sewer pipes, gas lines etc.)

#### Supplied with:

- 1x 460mm lid complete with:
  - 300mm high lid extension
- 2x 560mm lids complete with:
  - 150mm high lid extensions
- 3) Inlet fitted with:
  - 110mm socket
  - 110mm rubber gasket
  - 110mm (d) x 300mm (l) PVC pipe
- 4) 3x Inter connections fitted with:
  - 6x 110mm interconnecting gaskets (one on each side of the connections)
  - 3x 110mm (d) x 300mm (l) interconnecting PVC pipes

### Availability:

Standard colour ●

**Agreement Certified**  
**25-year guarantee**

Dimensions are in millimeters and the drawings are drawn on a scale of 1:75. The design is the property of Calcamite.