

Underground Modular Water Tank

5500L

The distinct crinkle-cut design of our modular tanks provides customisable and scalable underground water storage solutions that are quick to commission and easy to install.

Side view

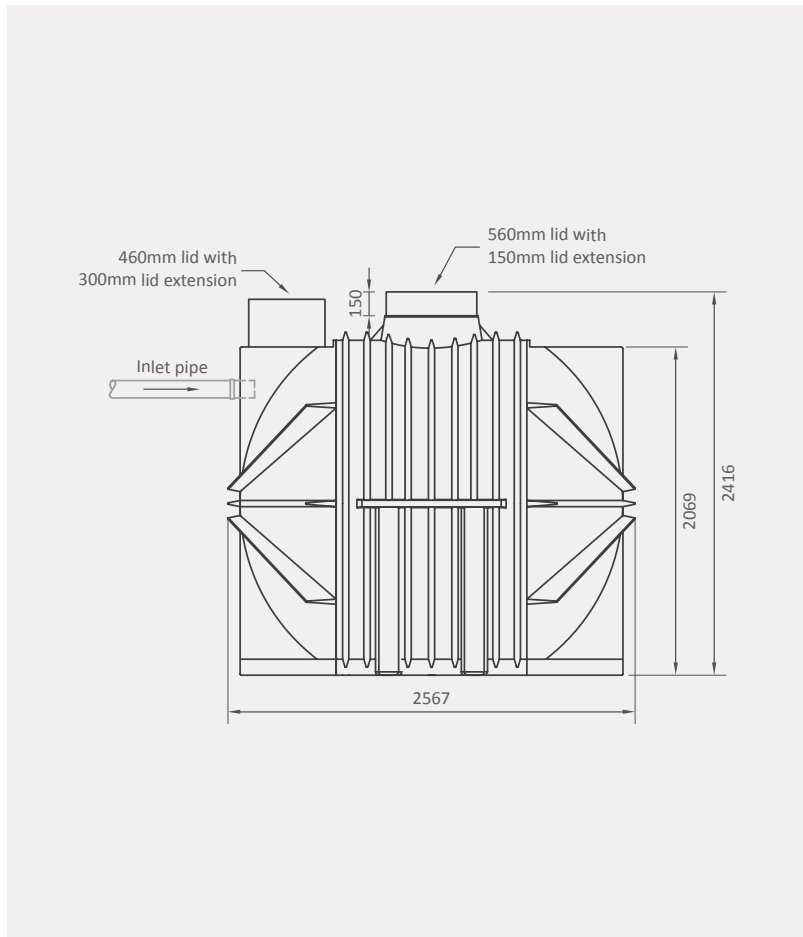

Top view

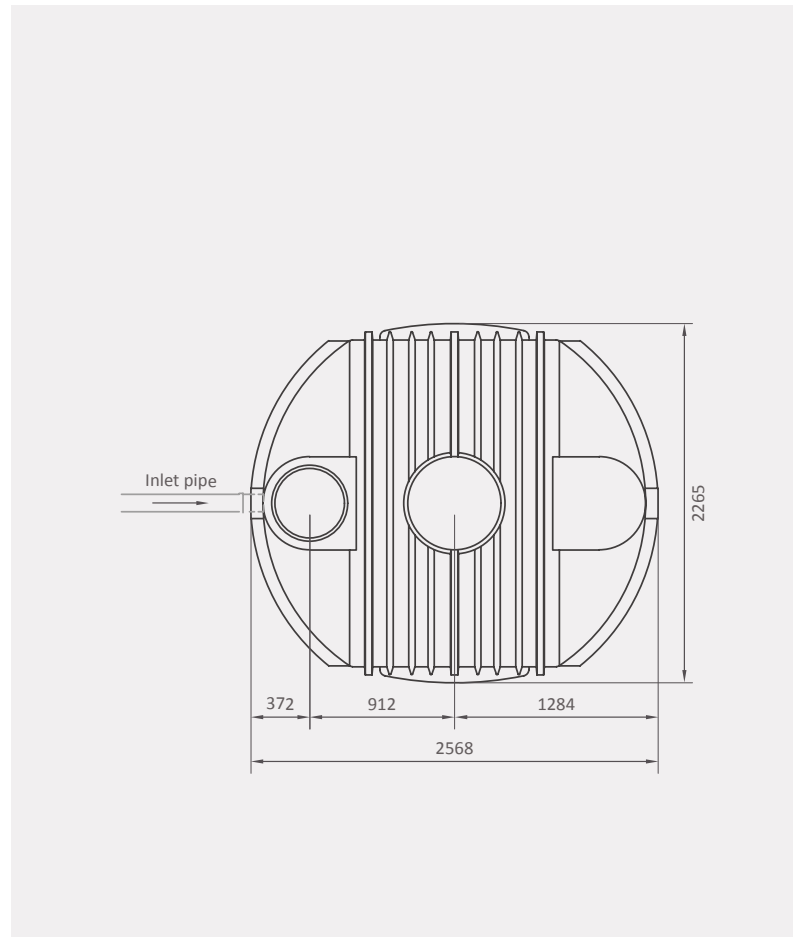

Product specifications:

Application:

- Below ground water storage

Supplied with:

- 1x 460mm lid complete with:
 - 300mm high lid extension
- 1x 560mm lid complete with:
 - 150mm high lid extension
- 3) Inlet fitted with:
 - 110mm socket
 - 110mm rubber gasket
 - 110mm (d) x 300mm (l) PVC pipe

Availability:

Standard colour ●

Agreement Certified
25-year guarantee

Dimensions are in millimeters and the drawings are drawn on a scale of 1:75. The design is the property of Calcamite.