

Vertical Water Tank

2500L

Our vertical water tank range is ideal for water storage, rainwater harvesting, or for applications where a supplementary or backup water supply is required.

Front view

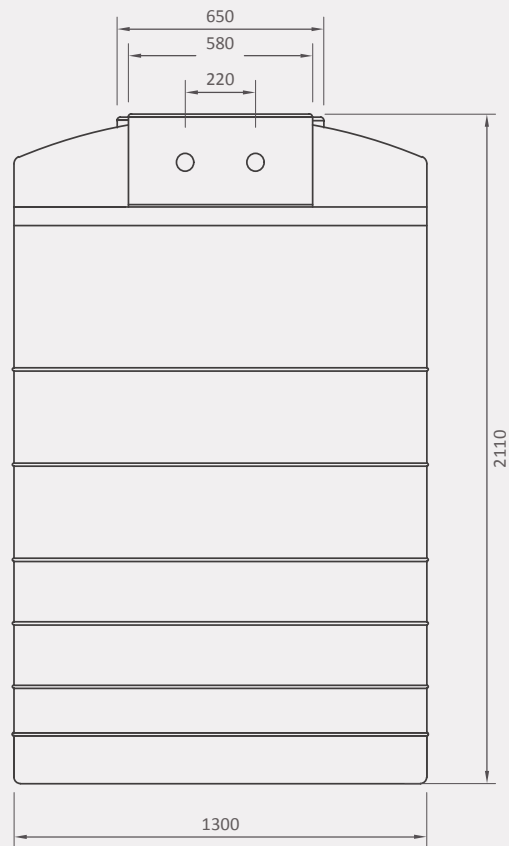

Top view

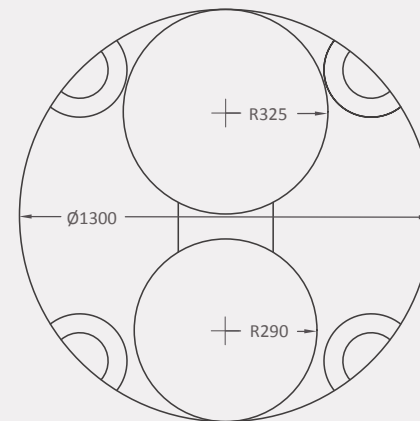

Product specifications:

Application:

- Above ground water storage
- Domestic use

Supplied with:

- 1) 500mm screw-on lid
- 2) Inlet fitted with:
 - 20mm female water tank fitting
 - 20mm thumb end plug
- 3) Outlet fitted with:
 - 20mm female water tank fitting
 - 20mm plastic tap
- 4) 2x Overflows fitted with:
 - 50/40mm reducer
 - 40mm thumb end plug

Availability:

Standard colours



Agrement South Africa certification
10-year guarantee

Dimensions are in millimeters and the drawings are drawn on a scale of 1:75. The design is the property of Calcamite.