

Bio-mite

BM4

Our range of Bio-mites are wastewater treatment plants that process wastewater to a specified quality, typically to reuse for irrigation and other non-potable applications.

Front view

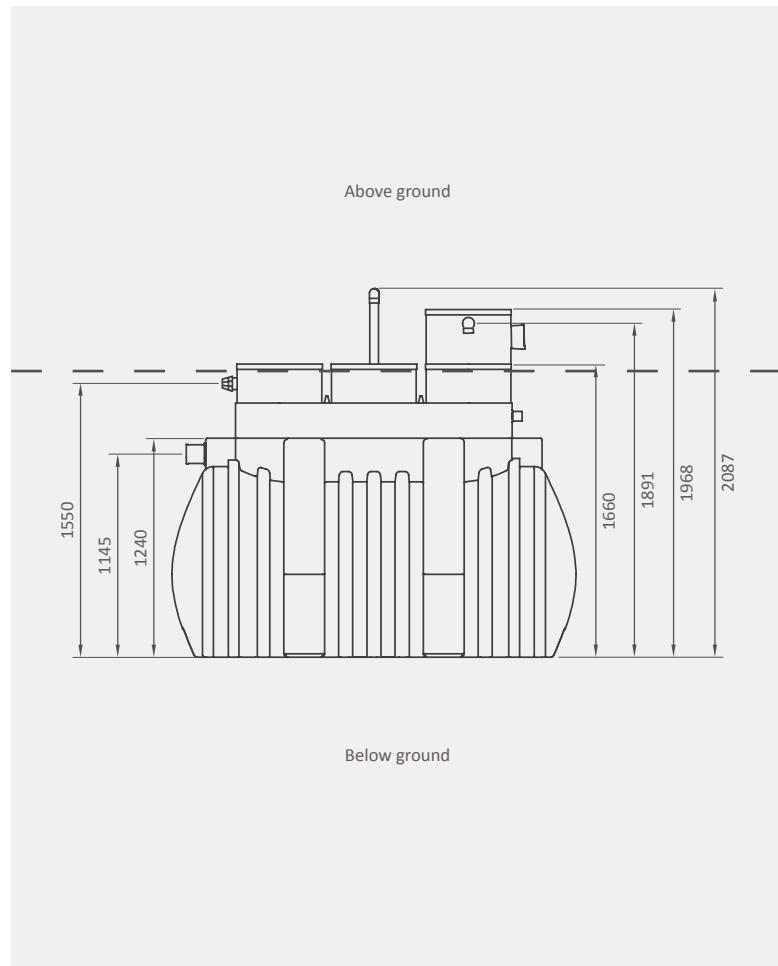

Top view

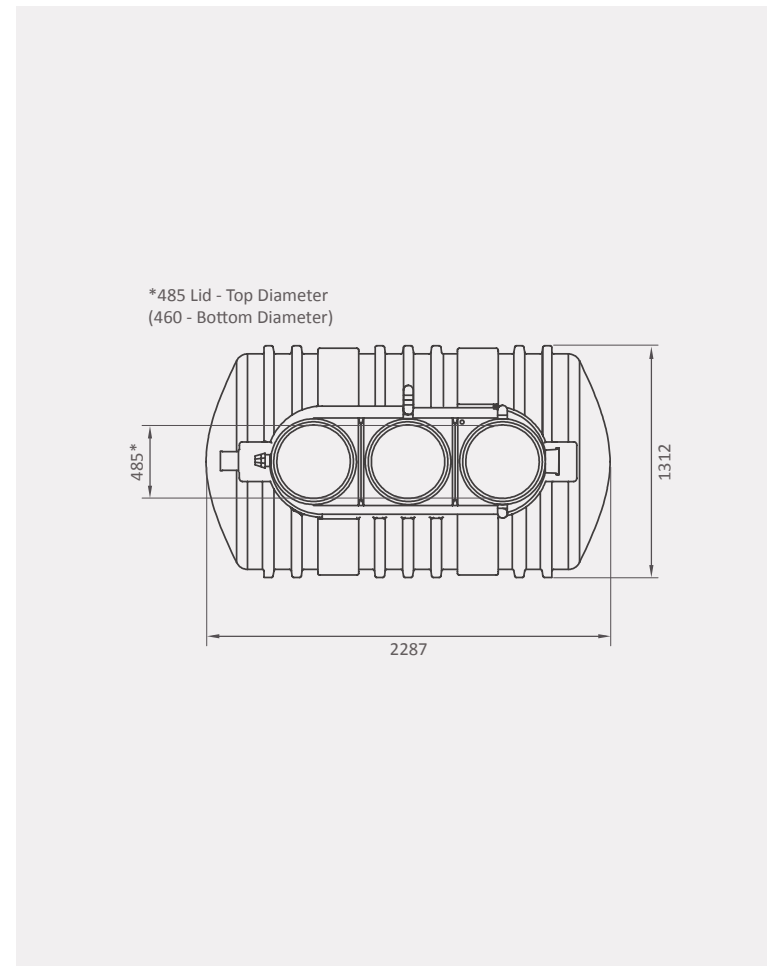

Product specifications:

Application:

- Below ground wastewater treatment plant
- Allows you to manage and safely reuse domestic wastewater for non-potable applications

Capacity:

- Up to 4 people (1KL/day)

Loading rate:

- 0.24kg/day (B.O.D./day)

Electricity use:

- 0.61kW

Supplied with:

- 1) 2x 460mm lids complete with:
 - 200mm high lid extensions
- 2) 1x 460mm lid complete with:
 - 200mm plus 300mm high lid extension
- 3) 50mm breather pipe
- 4) 1x inner chamber with all required internal plumbing
- 5) Inlet fitted with:
 - 110mm junction
 - 110mm screw cap
- 6) Outlet fitted with:
 - 40mm female compression fitting
 - 50mm PVC single socket (emergency overflow)
 - Chlorine dispenser with cartridge
 - Submersible pump (DAB Feka 550 VS)
- 7) Electrical components:
 - Hi-blow Blower
 - PS2 Box
 - Double wall plug

Availability:

Standard colour ●

25-year guarantee*

* This guarantee excludes all electrical components, these carry the supplier guarantees which are available on request.

Dimensions are in millimeters and the drawings are drawn on a scale of 1:50. The design is the property of Calcamite.