

## Septic Tank - SABS

1500L

Our distinctive, SABS-certified septic tanks incorporate the use of a double chamber to ensure better hydraulic efficiency, cleaner effluent discharge, and an improved soak-away performance.

### Front view

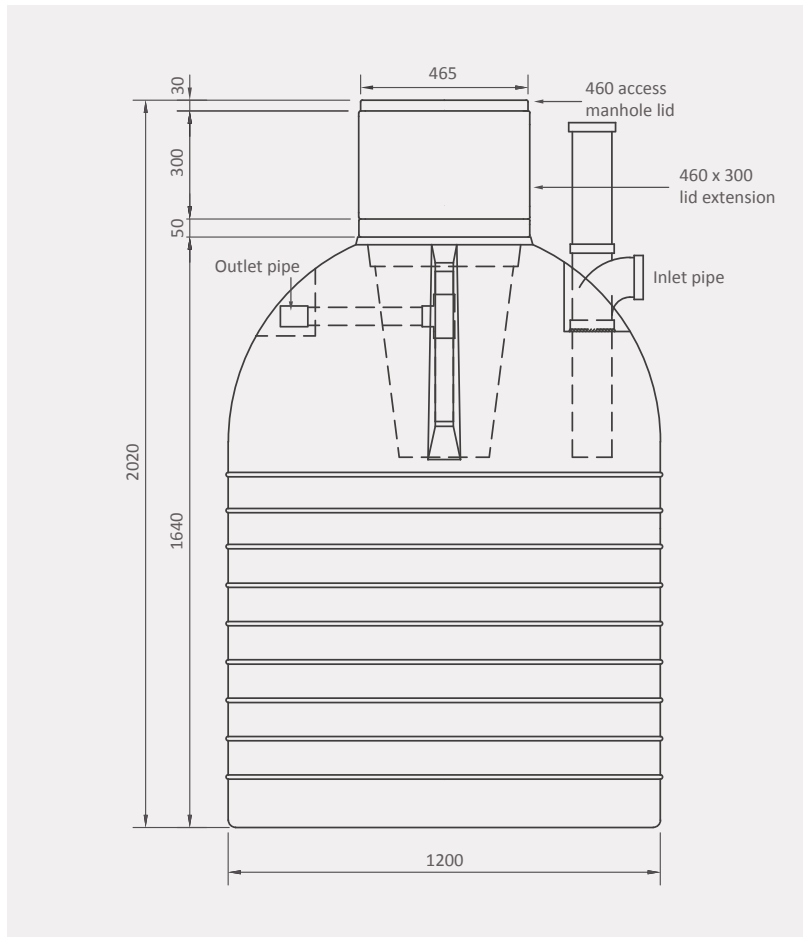

### Top view

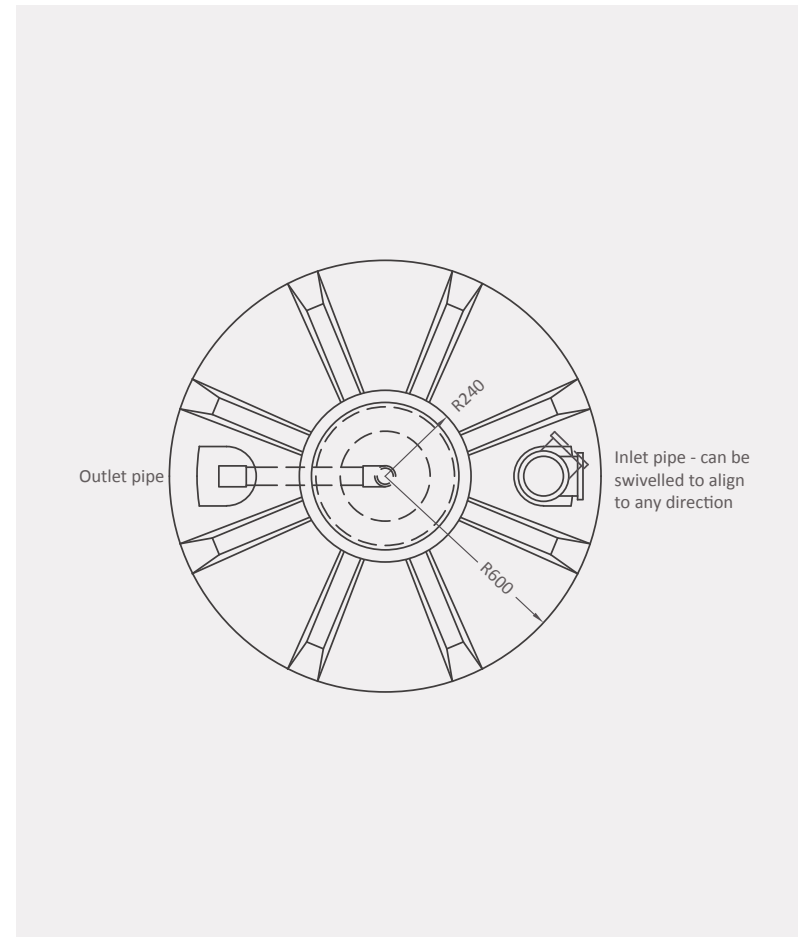

### Product specifications:

#### Capacity:

- Maximum of 6 people assuming 200L per person per day

#### Application:

- Below ground
- Where connection to the sewer line is not feasible/possible
- Soils with a good percolation rate such as sandy soil
- Areas with a low water table in order to prevent contamination of groundwater sources

#### Supplied with:

- 1) 110mm junction
- 2) 110mm screw cap (rodding eye)
- 3) 50mm socket
- 4) 110mm rubber gasket
- 5) 50mm rubber gasket
- 6) 110mm (d) x 400mm (l) inlet PVC pipe
- 7) 50mm (d) x 650mm (l) outlet PVC pipe
- 8) 460mm (d) x 300mm (h) extension
- 9) 460mm lid
- 10) 1 x inner chamber with all required internal plumbing

### Availability:

Standard colour ●

SABS Certified | 10-year guarantee

Dimensions are in millimeters and the drawings are drawn on a scale of 1:75. The design is the property of Calcamite.