

## Underground Modular Septic Tank

5500L

Ideal for installations where increased storage capacity is required, our modular septic tanks incorporate the same double chamber design as our standard septic range, allowing for cleaner effluent discharge than conventionally built septic tanks.

Side view

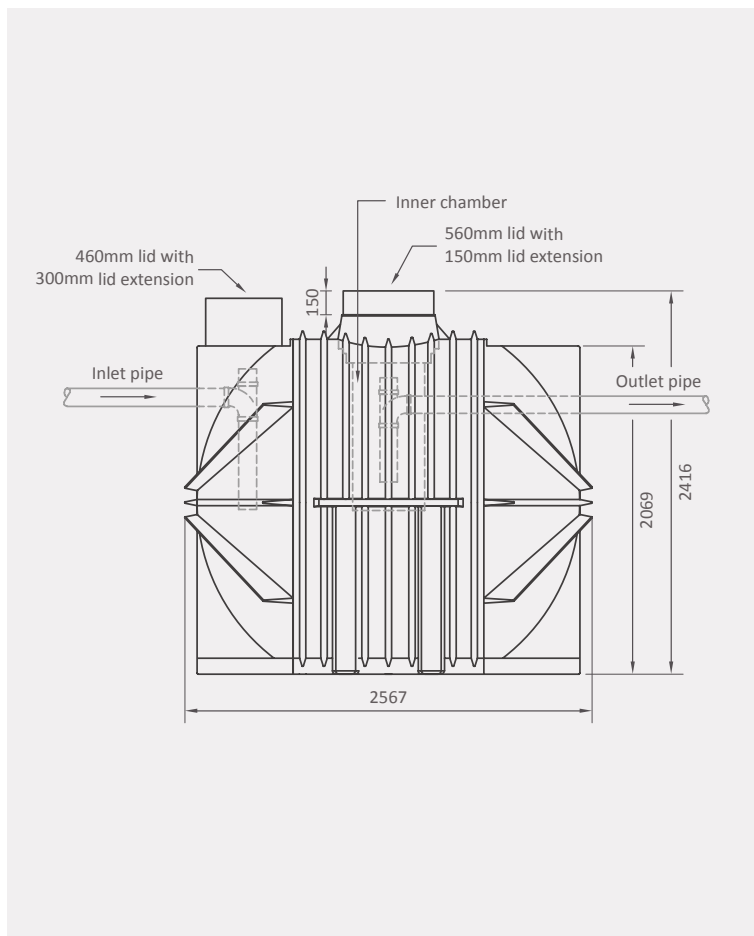

Top view

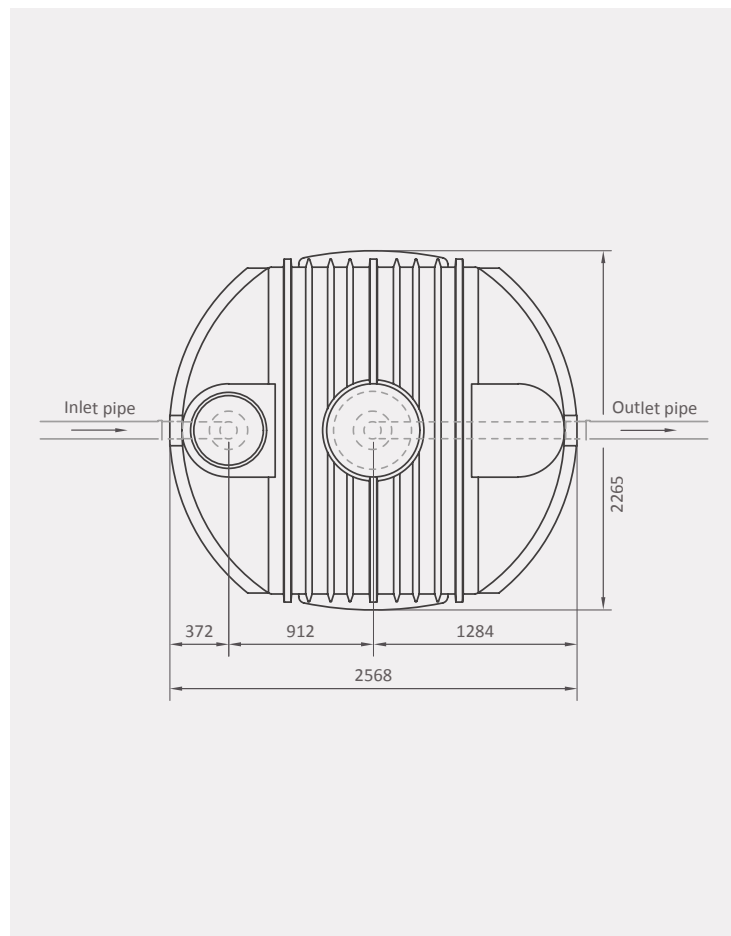

### Product specifications:

#### Capacity:

- Up to 28 people

#### Application:

- Below ground
- Where connection to the sewer line is not feasible/possible
- Soils with a good percolation rate such as sandy soil
- Areas with a low water table in order to prevent contamination of groundwater sources

#### Supplied with:

- 1) 1x 460mm lid complete with:
  - 300mm high lid extension
- 2) 1x 560mm lid complete with:
  - 150mm high lid extension
- 3) 1x inner chamber with all required internal plumbing
- 4) Inlet fitted with:
  - 110mm socket junction
  - 110mm rubber gasket
  - 110mm (d) x 300mm (l) PVC pipe
- 5) Outlet fitted with:
  - 110mm socket
  - 110mm rubber gasket
  - 110mm (d) x 300mm (l) PVC pipe

### Availability:

Standard colour ●

**Agrément Certified**  
**25-year guarantee**

Dimensions are in millimeters and the drawings are drawn on a scale of 1:75. The design is the property of Calcamite.