

Eco-mite

Maxi

Our waterless Eco-mite toilets enable flushing without a sewer connection and were specifically designed to protect both surface and groundwater by converting faeces into organic compost or soil conditioner.

Side view

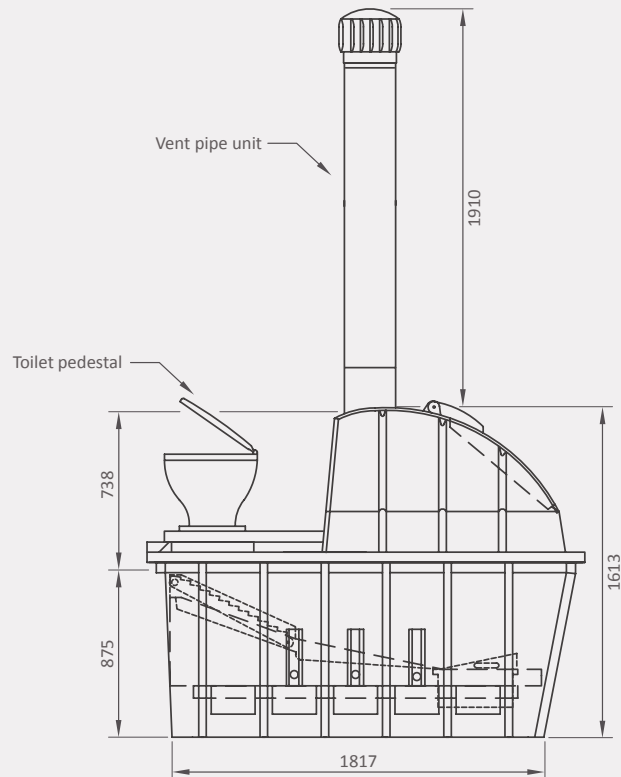

Top view

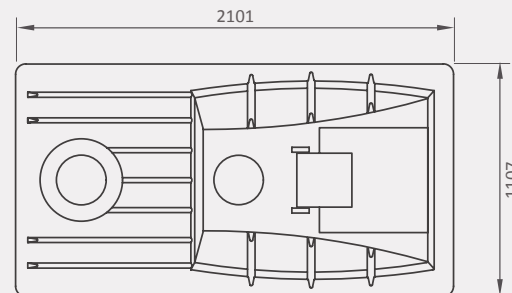

Product specifications:

Capacity:

- Maximum of 6 - 20 people

Application:

- Areas where access to water and sewer connections are limited or not feasible.

Supplied with:

- 1) Polyethylene base complete with:
 - Toilet pedestal
 - Urine diversion unit
- 2) Polyethylene drying plate
- 3) Polyethylene solar dome with hinge lid
- 4) 340mm vent pipe
- 5) Wind master/Extractor

Availability:

Standard colour ●

10-year guarantee

All dimensions are in millimetres and the drawings are drawn on a scale of 1:50. The design is the property of Calcamite.